

LSWE Technical Specification Data Sheet

AMET is pleased to provide the following technical specification for the LSW “standard” elevating style seam welder. The seam welder supplied to the customer will adhere to these specifications, unless modified in the proposal offered to the customer.

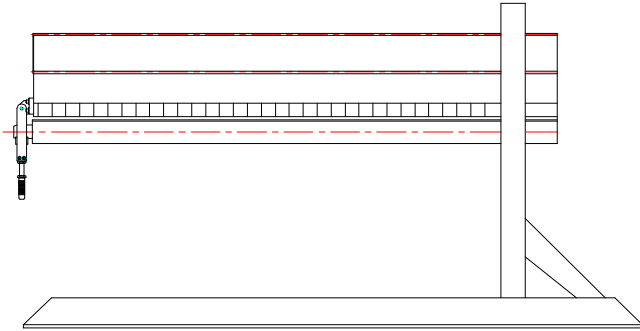

GENERAL SPECIFICATIONS & FEATURES

Nominal Weld Length	As specified in the Model Number of the system
Maximum Weld Length	Nominal weld length plus 4” (100 mm), allowing for run on/off tabs
Minimum Diameter	Dependent on weld length, please see chart on second page
Maximum Diameter	96” (2400 mm)
Wall Thickness	.020 to 3/8” (0.5 to 10 mm)

TRACK & CARRIAGE ASSEMBLY:

Track Accuracy	+/- 0.015” per 10ft of weld length (+/- 0.4 mm per 3 meter)
Track Design	Machined Structural Tube, fitted with linear square rails (THK style) on top and bottom
Track Adjustment	Included to provide required alignment with table top assembly
Carriage Speed	A = 4 to 150 IPM (100 to 3800 mm/min) B = 2 to 75 IPM (50 to 1900 mm/min)
Carriage Drive	Precision Gear rack with pinion gear
Carriage Motor	DC motor
Closed Loop Feedback	Included, using encoder
Speed Accuracy	+/- 1 % of set speed or better
Carriage Weight Cap.	330 lbs (150 kg) out 12” (300 mm) from carriage face
Carriage Face Dimension	14” x 27” (360 x 680 mm) minimum
Limit Switches	Included – home, end of weld and end of travel

Carriage Control	QII, XMS and XM controls with DSP technology (See controller tech Specs for more details)
------------------	--

Cable Carrier	Included
Torch Mount Bracket	Optional

TABLE TOP & MANDREL ASSEMBLY:

Water-cooled Mandrel	Included (cooler is optional)
Mandrel Adjustment	Included to handle various material thickness and for proper alignment
Mandrel Latch	Included, with safety switch and adjustment ability to insure mandrel is level
Insert	Includes one standard copper insert, with machined groove as specified
Clamping Activation	Hand Pendant, unless tape switch or foot switches are requested
Clamping Force	Adjustable, up to 5000 lbs/ft (75 kg/cm)
Clamping Control	PLC
Safety Interlocks	Included – one to prevent clamping if mandrel latch is not engaged and the other is to prevent unclamping during welding (requires arc-on signal)
Clamping Fingers	Aluminum with reversible & replaceable copper finger tips
Finger Adjustment	1/8” to 1.2” (3 to 30 mm) Optional: 0.55” to 1.73” (14 to 44 mm)
Clamping Design	Air, using one clamping hose per side
Centering devices	Includes two manually operated devices which can be located along the weld length incrementally
Vertical Assembly	Heavy-duty support structure and base. A hydraulic cylinder is used to lift table top to desired height. Table top is then pinned into position for safety (on 6”/150 mm increments)

SERVICE REQUIREMENTS:

Air Requirements	80 PSI (8 kg/sq.cm or 0.6 MPa)
Power Requirements	120 or 220 volts, 50/60 hz, 1 ph (350 watts maximum) and 460 volts, 60 hz, 3 phase or 380 volts, 50 hz, 3 phase (for hydraulic pump)

LSWE Technical Specification Data Sheet

LSWE Standard Elevating Style Seam Welders

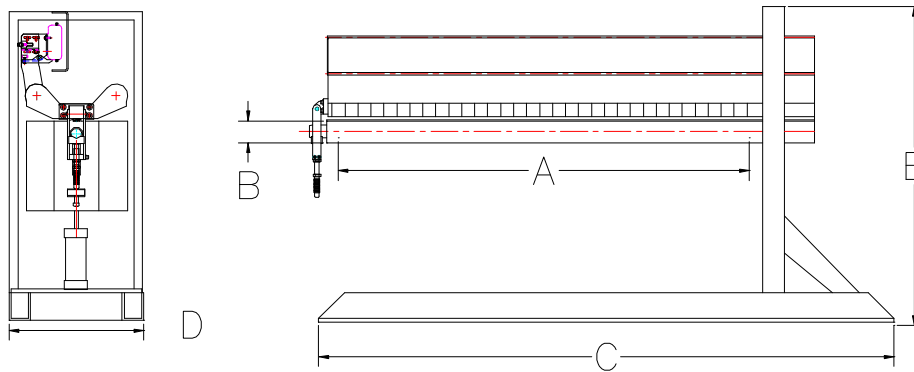

Model Number	"A" Welding Length *	"B" Min. Part Diameter **	"C" Overall Length	"D" Overall Width	"E" Overall Height***	Approx. Shipping Weight - Kg(lb)
LSWE-1200	1200 (47.2)	110 (4.33)	2385 (94)	1220 (48)	2920 (115)	1920 (00)
LSWE-1500	1500 (59.0)	135 (5.31)	2690 (106)	1220 (48)	2920 (115)	2230 (85)
LSWE-1800	1800 (70.8)	155 (6.10)	3000 (118)	1220 (48)	2920 (115)	2500 (80)
LSWE-2100	2100 (82.6)	175 (6.89)	3300 (130)	1220 (48)	2920 (115)	2625 (00)
LSWE-2400	2400 (94.4)	185 (7.28)	3580 (141)	1220 (48)	2920 (115)	3100 (00)
LSWE-2700	2700 (106.3)	215 (8.47)	3880 (153)	1370 (54)	3175 (125)	5325 (00)
LSWE-3000	3000 (118.2)	245 (9.65)	4180 (165)	1370 (54)	3175 (125)	5555 (00)
LSWE-3300	3300 (129.9)	280 (11.03)	4500 (177)	1370 (54)	3175 (125)	5780 (00)
LSWE-3600	3600 (141.7)	315 (12.41)	5070 (199)	1370 (54)	3175 (125)	6000 (00)
LSWE-3900	3900 (153.5)	355 (13.97)	5390 (210)	1370 (54)	3175 (125)	6240 (00)
LSWE-4200	4200 (165.3)	390 (15.36)	5640 (222)	1370 (54)	3175 (125)	6450 (00)

* All models include an extra 50 mm (2") weld length on each end for Run On/Off tabs

** Minimum Part Diameter when table is in fully extended position is 96" (2400 mm)

*** Due to overall height of system, we have to dismantle the mainstay and ship the seam welder in section due to height restrictions in shipping.

Note: All Elevating seam welders require a pit beneath the mainstay section for the hydraulic cylinder. The mainstay will be to be properly anchored to the factory floor. Please consult factory for details.

On weld lengths beyond 4200 mm, please contact factory for specifications and pricing.

AMET-TS-LSWE-0105