

# LSW-P Technical Specification Data Sheet

AMET is pleased to provide the following technical specification for the LSW "precision" external style seam welder. The seam welder supplied to the customer will adhere to these specifications, unless modified in the proposal offered to the customer.

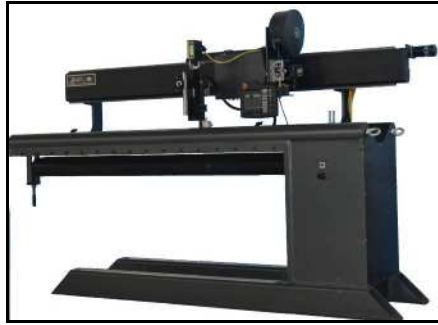

## GENERAL SPECIFICATIONS & FEATURES

Nominal Weld Length	As specified in the Model Number of the system
Maximum Weld Length	Nominal weld length plus 4" (100 mm), allowing for run on/off tabs
Minimum Diameter	Dependent on weld length, please see chart on second page
Maximum Diameter	36" (910 mm) (optional riser section can be added to increase this capacity)
Wall Thickness	.020 to 3/8" (0.5 to 10 mm)

## TRACK & CARRIAGE ASSEMBLY:

Track Accuracy	+/- 0.005" per 10ft of weld length (+/- 0.15 mm per 3 meter)
Track Design	Machined Structural Tube, fitted with linear square rails (THK style) on top and bottom
Track Adjustment	Included to provide required alignment with table top assembly
Carriage Speed	0.2 to 87 IPM (5 to 2210 mm/min) (other speed ranges are available as special order)
Carriage Drive	Precision ball screw & nut on weld lengths up to 10 ft. (3 meters). On welds lengths above 3 meters, AMET uses extra precision, servo grade gear rack and pinion gear drive. For an extra fee, we can use a very special ball screw drive up to 20 ft (6 M) stroke
Carriage Motor	DC Servo motor
Closed Loop Feedback	Included, using encoder
Speed Accuracy	+/- 0.5 % of set speed or better
Carriage Weight Cap.	330 lbs (150 kg) out 12" (300 mm) from carriage face

Carriage Face Dimension	14" x 27" (360 x 680 mm) minimum
Limit Switches	Included – home and end of travel
Carriage Control	QII, XMS and XM controls with DSP technology <i>(See controller tech Specs for more details)</i>
Cable Carrier	Included
Torch Mount Bracket	Optional

## TABLE TOP & MANDREL ASSEMBLY:

Water-cooled Mandrel	Included (cooler is optional)
Mandrel Adjustment	Included to handle various material thickness and for proper alignment
Mandrel Latch	Included, with safety switch and adjustment ability to insure mandrel is level
Insert	Includes one standard copper insert, with machined groove as specified
Clamping Activation	Tape switch, unless hand pendant or foot switches are requested
Clamping Force	Adjustable, up to 5000 lbs/ft (75 kg/cm)
Clamping Control	PLC
Safety Interlocks	Included – one to prevent clamping if mandrel latch is not engaged and the other is to prevent unclamping during welding (requires arc-on signal)
Clamping Fingers	Aluminum with reversible & replaceable copper finger tips
Cont. Clamping Strips	Included
Finger Adjustment	1/8" to 1.2" (3 to 30 mm) Optional: 0.55" to 1.73" (14 to 44 mm)
Clamping Design	Air, using one clamping hose per side
Centering devices	Includes two manually operated devices which can be located along the weld length incrementally
Vertical Mainstay	Welded to base assembly. Option - bolted so maximum diameter capacity can be increased in the future.

## SERVICE REQUIREMENTS:

Air Requirements	80 PSI (8 kg/sq.cm or 0.6 MPa)
Power Requirements	120 or 220 volts, 50/60 hz, 1 ph (350 watts maximum)

# LSW-P Technical Specification Data Sheet

## LSW-P Precision Style Seam Welders

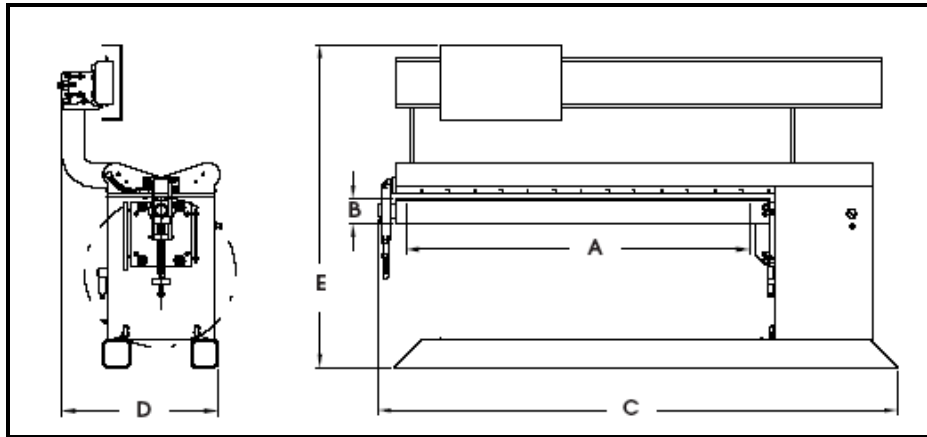

Model Number	"A" Welding Length *	"B" Min. Part Diameter **	"C" Overall Length	"D" Overall Width***	"E" Overall Height	Approx. Shipping Weight - Kg(lb)
LSW-P-600	600 (23.6)	70 (2.76)	1780 (70)	1050 (42)	1850 (73)	1090 (2400)
LSW-P-750	750 (29.5)	80 (3.15)	1930 (76)	1050 (42)	1850 (73)	1160 (2550)
LSW-P-900	900 (35.4)	90 (3.55)	2080 (82)	1050 (42)	1850 (73)	1230 (2700)
LSW-P-1050	1050 (41.3)	100 (4.00)	2235 (88)	1050 (42)	1850 (73)	1550 (3400)
LSW-P-1200	1200 (47.2)	110 (4.33)	2385 (94)	1050 (42)	1850 (73)	1820 (4000)
LSW-P-1500	1500 (59.0)	135 (5.31)	2690 (106)	1050 (42)	1850 (73)	2130 (4685)
LSW-P-1800	1800 (70.8)	155 (6.10)	3000 (118)	1050 (42)	1850 (73)	2400 (5280)
LSW-P-2100	2100 (82.6)	175 (6.89)	3300 (130)	1050 (42)	1850 (73)	2725 (6000)
LSW-P-2400	2400 (94.4)	185 (7.28)	3580 (141)	1050 (42)	1850 (73)	3000 (6500)
LSW-P-2700	2700 (106.3)	215 (8.47)	3880 (153)	1120 (44)	2030 (80)	5225 (11,500)
LSW-P-3000	3000 (118.2)	245 (9.65)	4180 (165)	1120 (44)	2030 (80)	5455 (12,000)
LSW-P-3300	3300 (129.9)	280 (11.03)	4500 (177)	1120 (44)	2030 (80)	5680 (12,500)
LSW-P-3600	3600 (141.7)	315 (12.41)	5070 (199)	1120 (44)	2030 (80)	5900 (13,000)
LSW-P-3900	3900 (153.5)	355 (13.97)	5390 (210)	1120 (44)	2030 (80)	6140 (13,500)
LSW-P-4200	4200 (165.3)	390 (15.36)	5640 (222)	1120 (44)	2030 (80)	6350 (14,000)
LSW-P-4500	4500 (177.1)	420 (16.54)	6000 (235)	1120 (44)	2030 (80)	6590 (14,500)
LSW-P-4800	4800 (188.9)	470 (18.51)	6300 (248)	1120 (44)	2030 (80)	6820 (15,000)
LSW-P-5100	5100 (200.7)	505 (19.89)	6580 (259)	1120 (44)	2030 (80)	7045 (15,500)
LSW-P-5400	5400 (212.6)	540 (21.26)	6860 (270)	1120 (44)	2030 (80)	7250 (16,000)
LSW-P-5700	5700 (224.4)	580 (22.84)	7165 (282)	1120 (44)	2030 (80)	7500 (16,500)
LSW-P-6000	6000 (236.2)	615 (24.22)	7490 (295)	1120 (44)	2030 (80)	7700 (17,000)

- \* All models include an extra 50 mm (2") weld length on each end for Run On/Off tabs
- \*\* Maximum Part Diameter is 910 mm (36") on all models
- \*\*\* Overall width does not include cable carrier, add an extra 6" (150 mm) for the cable carrier

AMET-TS-LSWP-0205