

XM Controls



The neXt Generation of Automated Welding Systems and Standalone Components

XM 200 X-LWS

The XM 200 X-LWS is a precision “turn-key” programmable lathe bed welding station. It combines the intelligent XM Controller with AMET’s precision harmonic drive lathe. All Welding equipment are mounted or housed on an industrial workstation with available single point power distribution.

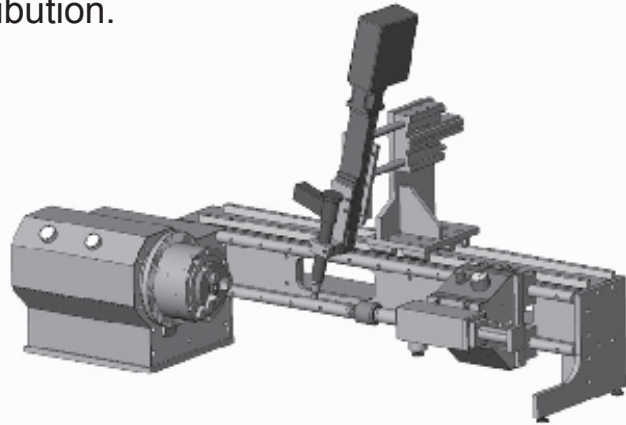
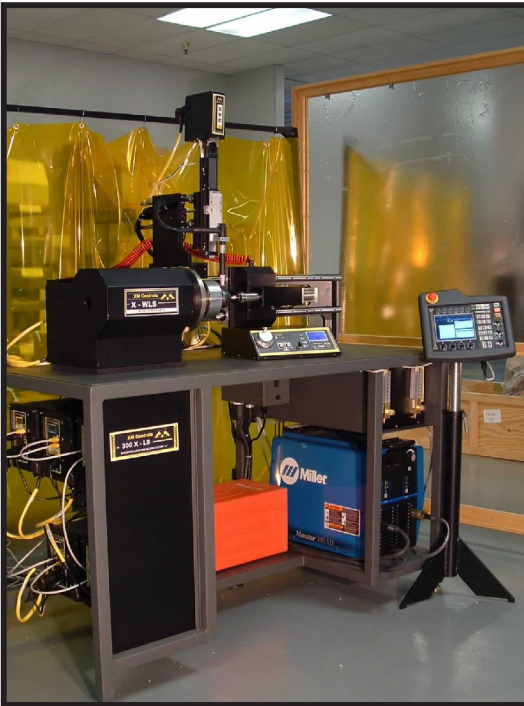

FEATURES

- XM** All in one design & construction with single point power for easy setup & operation.
- XM** Powerful XM controller for precision control and outstanding Operator feedback.
- XM** Integrates to virtually any GTA, GMA, or PAW welding power supply.
- XM** Integrated Precision Benchtop Lathe, 8” part Dia. and 18” part length capacity.
- XM** Rugged industrial table with all controls within easy reach.
- XM** Optional XVC (arc voltage control), X-feeder (wire feed), X-slide (oscillation).
- XM** Optional Motorized wire feed manipulator.

